

PARTS MANUAL

**Air Conditioning/Heat Pump
Outdoor Unit**

AC OUTDR 5U34HS2ERA

Product Code
51044-A

AU NZ

Haier

CONTENTS

INTRODUCTION	2
AC COMPONENTS	3

INTRODUCTION

BRAND	VOLTAGE	MODEL	PRODUCT CODE
Haier	220-240V 50Hz	AC OUTDR 5U34HS2ERA	51044-A

MODELS

- ▮ The models covered by this manual are listed on the front cover.
- ▮ The information detailed in this manual is subject to change without notice. The latest version is indicated by the reprint date and replaces any earlier editions.

KIT PARTS

Where a part number is shown against the descriptions for these kit components, they are also available as separate items. In addition, some parts may be supplied with these kits that are not available as separate items, and are therefore either not listed, or a part number is not shown against the part description in this manual.

PARTS LIST KEY

NI	As a part reference, indicates the part is not illustrated on the diagram.
NOT USED	As a part number, indicates the diagram part reference is not used in this manual.
NS	As a part number, indicates the part is not servicable.

NZ

Fisher & Paykel Appliances Ltd
78 Springs Road, East Tamaki
Manukau 2013
PO Box 58-546 Botany
Manukau 2163
New Zealand

tel: 09 273 0600
fax: 09 273 0656
e-mail: nz.customercare@fisherpaykel.com

AU

Fisher & Paykel Customer Services Pty Ltd
PO Box 798, Cleveland, QLD 4163
A.C.N. 003 3335 171
19 Enterprise Street
Cleveland, QLD 4163
Australia

tel: 07 3826 9100
fax: 07 3826 9164
e-mail: aus.customercare@fisherpaykel.com

AC COMPONENTS

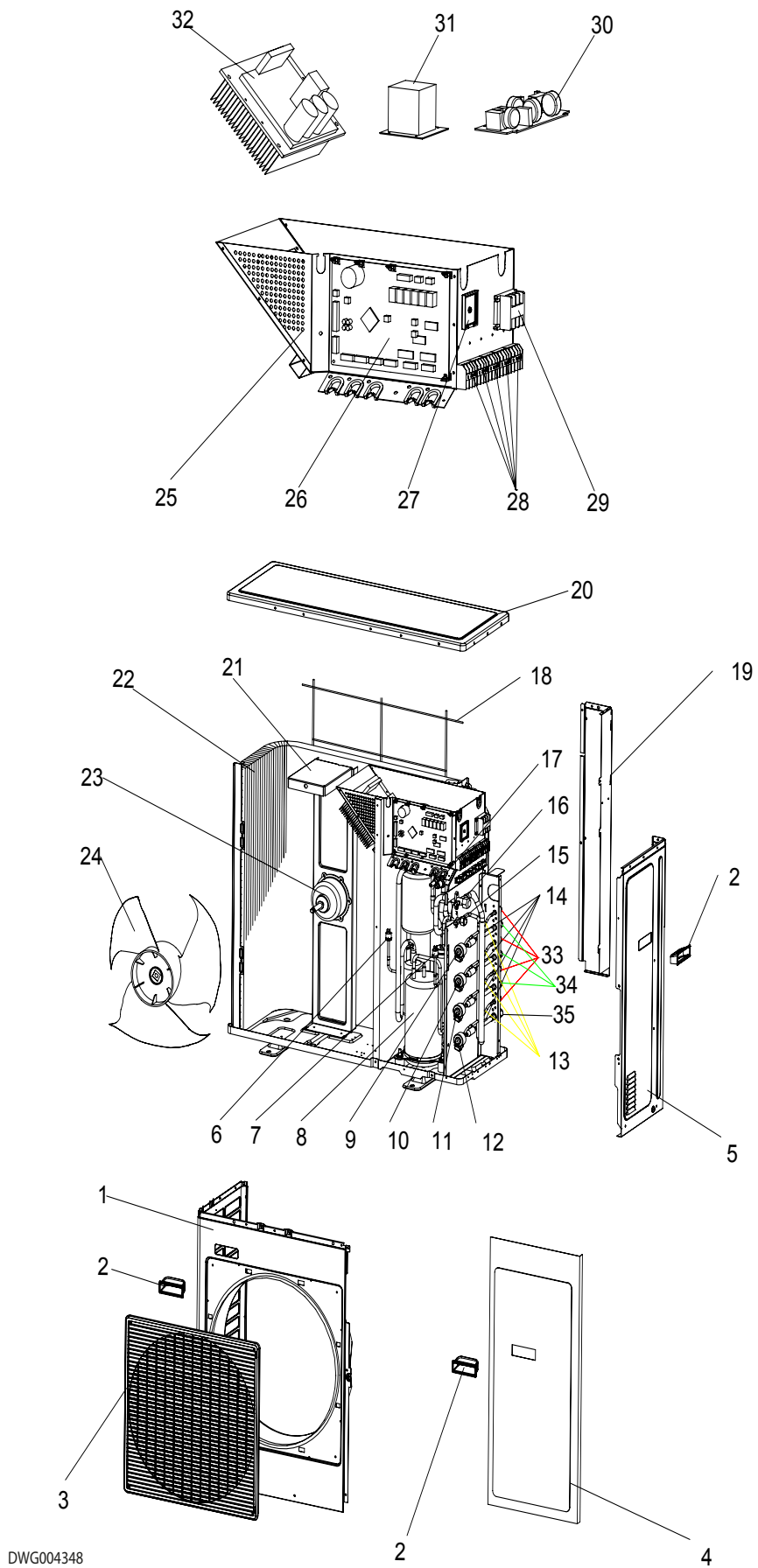

AC COMPONENTS

REFERENCE	PART NUMBER	PART DESCRIPTION
1	H0150822252	FRONT PANEL
2	H0150201648	HANDLE
2	H001A1436160	HANDLE
3	H0150201852	OUTLET GRILL
4	H0150802875	SERVICE PANEL FRONT
5	H0150802872	SERVICE PANEL RH
6	H0010451924	LOW PRESSURE SWITCH
7	H0150400474	HIGH PRESSURE SWITCH
8	H0010756371	COMPRESSOR
9	H0010757940	EXPANSION VALVE
9	H0010452290	LEV COIL
10	H0010757940	EXPANSION VALVE
10	H0010452292	LEV COIL ROOM B (YELLOW)
11	H0010757940	EXPANSION VALVE
11	H0010452290	LEV COIL
12	H0150702180	EXPANSION VALVE GROUP
13	H0010451305	LIQUID PIPE SENSOR
14	H0010452099	SENSOR GAS PIPE TEMP
15	H0150702891	LIQUID STOP VALVE
16	H0150702892	GAS STOP VALVE
17	H0010757602E	VALVE 4 WAY
18	H0150106085	BACK GRILL
19	H0150802874	REAR PANEL
20	H0150809461	TOP COVER
21	H0010101736	MOTOR BRACKET
22	H0150813074	CONDENSOR ASSY
23	H0010400771	FAN MOTOR (DC)
24	H0010205435A	AXIAL FAN FLOW HSU-30HEA03/R2
25	H0150825580	ELECTRICAL BOX ASSY
26	H0151800075C	PCB MAIN
27	H0151800076A	PCB SMALL SERVICE
28	H0010451783	TERMINAL BLOCK
29	H0010451258E	TERMINAL BLOCK FOR POWER SUPPL
30	H0150400699	FILTER PCB

AC COMPONENTS

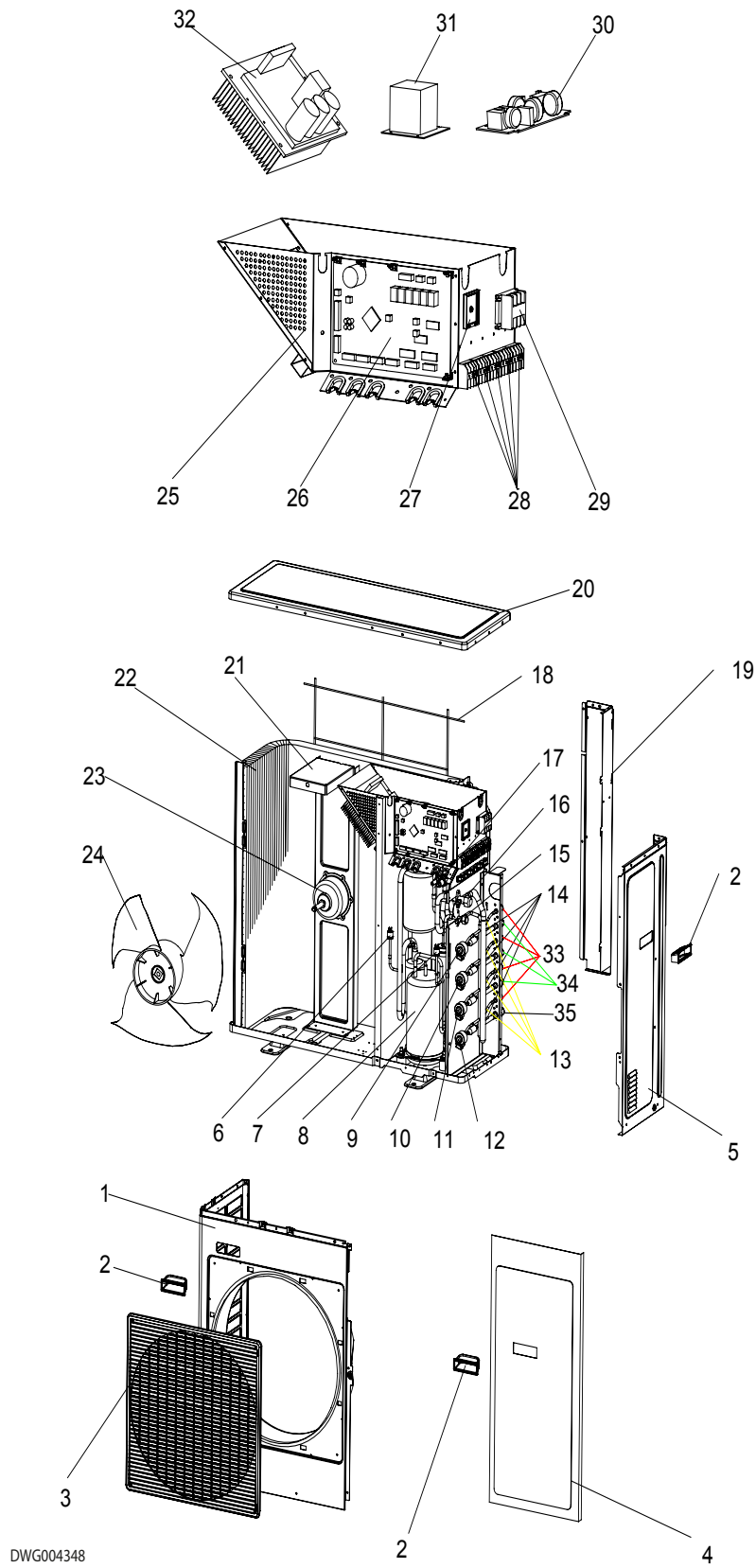

AC COMPONENTS

REFERENCE	PART NUMBER	PART DESCRIPTION
31	H0010403750EA	REACTOR
32-1	H0010404106	CAPACITOR PCB
32-2	H0150400908	INVERTER DRIVER MOD <18/7/16
	H0150401756A	INVERTER DRIVER MOD >18/7/16
33	H0150702893	LIQUID PIPE 1/4"-6,35
34	H0150702894	GAS PIPE 3/5"-9.52MM
35	H0150702895	GAS PIPE 1/2"-12,7,,
NI	H0010452538	SENSOR ASSY (DISC/SUCT/COND)
NI	H0010452538	SENSOR ASSY (DISC/SUCT/COND)
NI	H0010452538	SENSOR ASSY (DISC/SUCT/COND)
NI	H0010450194	DEFROSTING SENSOR
NI	H001A1434040	DRAINAGE ELBOW

www.fisherpaykel.com

Copyright © Fisher & Paykel 2017. All rights reserved.
The product specifications in this manual apply to the specific model described at the date of issue. Under our policy of continuous product improvement, these specifications may change at any time. Only use this manual if the product code on the front matches the product code on the serial label of the product.

AU NZ

PRODUCT CODE: 51044-A 03.17