

PARTS MANUAL

**Air Conditioning/Heat Pump
Outdoor Unit**

AC OUTDR 1UH071N1ERG

Product Code
51069-A

AU NZ

Haier

CONTENTS

INTRODUCTION	2
AC COMPONENTS	3

INTRODUCTION

BRAND	VOLTAGE	MODEL	PRODUCT CODE
Haier	220-240V 50Hz	AC OUTDR 1UH071NIERG	51069-A

MODELS

- The models covered by this manual are listed on the front cover.
- The information detailed in this manual is subject to change without notice. The latest version is indicated by the reprint date and replaces any earlier editions.

KIT PARTS

Kit components are shown in italics. Where a part number is shown against the descriptions for these kit components, they are also available as separate items. In addition, some parts may be supplied with these kits that are not available as separate items, and are therefore either not listed, or a part number is not shown against the part description in this manual.

PARTS LIST KEY

ITALICS	Kit components or parts included are shown in italics. Refer to above notes: Kit Parts.
NI	As a part reference, indicates the part is not illustrated on the diagram.
NOT USED	As a part number, indicates the diagram part reference is not used in this manual.
NS	As a part number, indicates the part is not servicable.

NZ

Fisher & Paykel Appliances Ltd
78 Springs Road, East Tamaki
Manukau 2013
PO Box 58-546 Botany
Manukau 2163
New Zealand

tel: 09 273 0600
fax: 09 273 0656
e-mail: nz.customercare@fisherpaykel.com

AU

Fisher & Paykel Customer Services Pty Ltd
PO Box 798, Cleveland, QLD 4163
A.C.N. 003 3335 171
19 Enterprise Street
Cleveland, QLD 4163
Australia

tel: 07 3826 9100
fax: 07 3826 9164
e-mail: aus.customercare@fisherpaykel.com

AC COMPONENTS

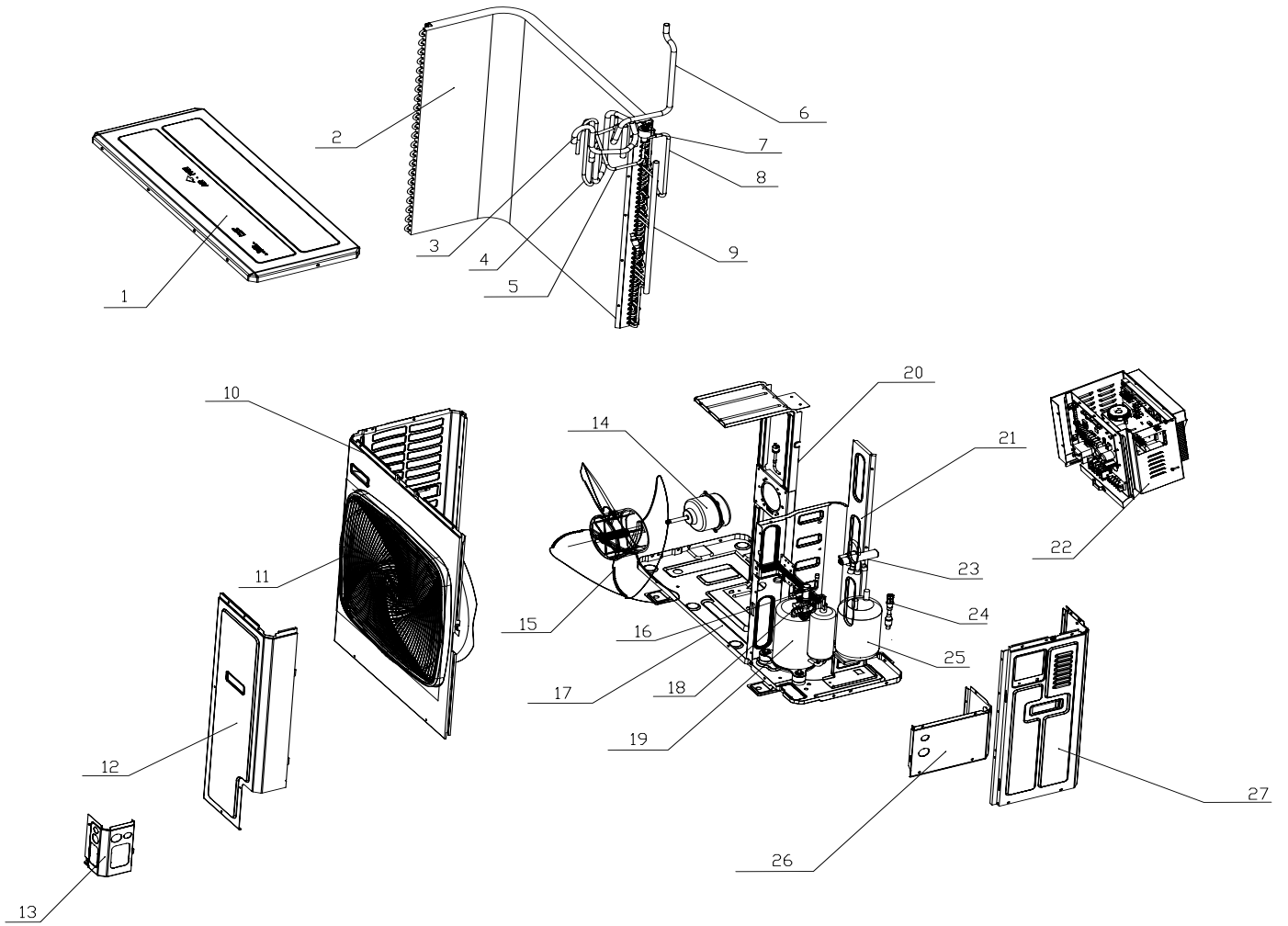

DWG004319

AC COMPONENTS

REFERENCE	PART NUMBER	PART DESCRIPTION
1	H0150822814	TOP COVER ASSY.
2	H0150715583	CONDENSOR ASSY.
3	H0150716261	SUCTION PIPE
4	H0150716260	DISCHARGE PIPE
5	H0150714726	EEV OUTLET PIPE
6	H0150716316	CONNECTION PIPE
7	H0150702181	ELECTRONIC EXPANSION VALVE
8	H0150716298	EEV INLET PIPE
9	H0150714720	COLLECTION PIPE
10	H0150106402	FRONT PANEL
11	H0150201850	OUTLET GRILL
12	H0150823490	MAINTENANCE PLATE
13	H0150106403	FIXING PLATE
14	H0150401804	FAN MOTOR
15	H0150201647	FAN
16	H0150710811	STOP VALVE
17	H0150107404	BOTTOM PAN
18	H0150714736	SERVICE VALVE
19	H0010719333	COMPRESSOR
20	H0150107407	MOTOR BRACKET
21	H0150107406	PARTION PLATE
22	H0150820811	ELECTRIC CONTROL BOX ASYY.
22	H0151800054B	MAIN CONTROL PCB
22	H0150401824	COMPRESSOR DRIVER BOARD
22	H0150401973	REACTOR
22	H0150402020	WIRE
22	H0010451258E	TERMINAL BLOCK FOR POWER SUPPLY
22	H0010451258E	TERMINAL BLOCK FOR INTER-CONNECT
22	H0010451303	DISCHARGE TEMPERATURE SENSOR TD
22	H0010451307	SUCTION TEMPERATURE SENSOR TS
22	H0010450194	DEFROSTTEMPERATURE SENSOR TE
22	H0010450192	OUTDOOR AMBIENT SENSOR TAO
22	H0010451329	OUTDOOR CONDENSER SENSOR TC
23	H0010757602E	4-WAY STOP VALVE
24	H0150714728	COLLECTION LIQUID PIPE
25	H0150714744	ACCUMULATOR
26	H0150106404	FIXING PLATE
27	H0150106407	RIGHT SIDE PLATE

www.fisherpaykel.com

Copyright © Fisher & Paykel 2017. All rights reserved.
The product specifications in this manual apply to the specific model described at the date of issue. Under our policy of continuous product improvement, these specifications may change at any time. Only use this manual if the product code on the front matches the product code on the serial label of the product.

AU NZ

PRODUCT CODE: 51069-A 03.17