

FISHER & PAYKEL

WARMER DRAWER

WB60SDEX1 FP AA

PRODUCT CODE: 81487-A

PARTS MANUAL

AA

Brand:	Fisher & Paykel
Voltage:	220-240V, 50H
Model:	WB60SDEX1 FP AA
Product Code:	81487-A

Model

- The model covered by this manual is listed on the front cover.
- The information detailed in this manual is subject to change without notice. The latest version is indicated by the reprint date and replaces any earlier editions.
- The front cover picture indicates the type of product. It may not be an exact image of the model covered in the manual.

Kit Parts

Kit components are shown in *italics*. Where a part number is shown against the descriptions for these kit components, they are also available as separate items. In addition, some parts may be supplied with these kits that are not available as separate items, and are therefore either not listed, or a part number is not shown against the part description in this manual.

Parts List Key

<i>italics</i>	Kit components or parts included are shown in italics. Refer to above notes: Kit Parts.
NI	As a part reference, indicates the part is not illustrated on the diagram.
NS	As a part reference indicates this part is not serviceable.
NOT USED	As a part number, indicates the diagram part reference is not used in this manual.

ENCLOSURE & DRAWER ASSEMBLY	3
CONTROLS & ELECTRICAL ASSEMBLY	5

Fisher & Paykel Appliances Ltd

PO Box 58-732,
Greenmount
78 Springs Rd,
East Tamaki
New Zealand

tel: (09) 2730660
fax: (09) 2730580
email: customer.care@fp.co.nz

Fisher & Paykel Customer Services Pty Ltd

PO Box 798, Cleveland, QLD 4163
A.C.N. 003 3335 171
19 Enterprise Street Cleveland,
QLD 4163
Australia

tel: (07) 3826 9100
fax: (07) 3826 9164
email: customer.care@fp.com.au

Fisher & Paykel Appliances Ltd

Singapore
150 Ubi Avenue 4
Sunlight building #02-00
Singapore 408825

tel: 6547 0100
service tel: 6741 0777
fax: 6547 0123

3 ENCLOSURE & DRAWER ASSEMBLY

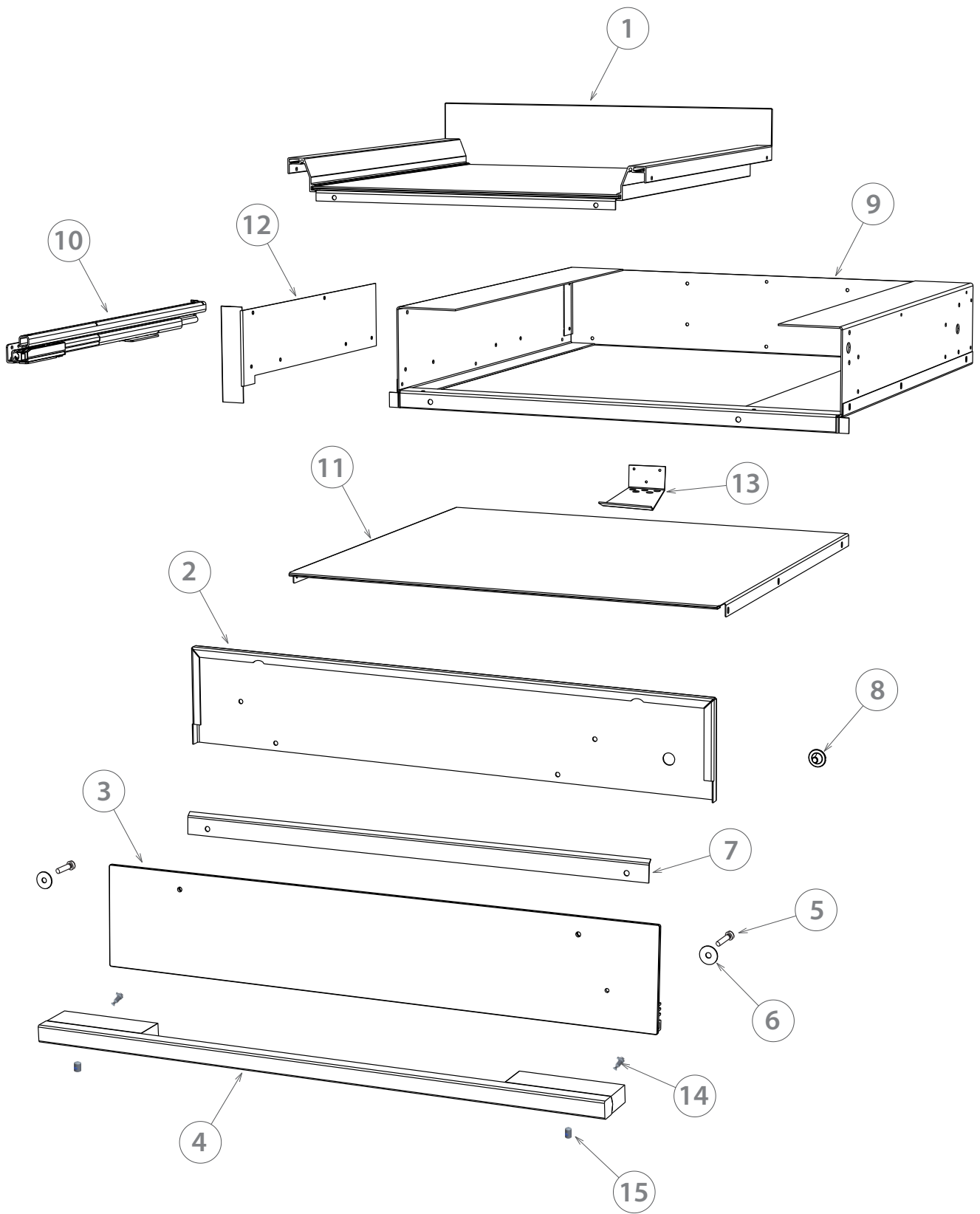

REF.	PART NUMBER	PART DESCRIPTION
1	570300	KIT DRAWER ASSY WD60/24 LGO
	<i>Includes</i>	GLASS DRAWER WD LOGO
	<i>Includes</i>	EXTRUSION WARMER DRAWER WD
	<i>Includes</i>	REAR FACIA DRAWER WD
	<i>Includes</i>	FRONT BRACKET DRAWER WD
2	570014	FRAME DOOR WD
NI	570064P	SCREW M4X10 TAPTITE PH PN PKT10
NI	570116P	SCREW M4X9 TAPT WAFER PH PKT10
3	570312	KIT DOOR FASCIA SS ASSY
	<i>Includes</i>	GLASS DOOR SS
	<i>Includes</i>	EXTRUSION DOOR BASE WB24
	<i>Includes</i>	DOOR SS WB24
	<i>Includes 542807P</i>	SCREW MC M5X20 PAN PH MS
	<i>Includes 570075P</i>	WASHER DOOR BRACKET WD
	<i>Includes 563100</i>	PIN LOCK FNT HANDLE
	<i>Includes 570074</i>	GROMMET DOOR GLASS WD
	<i>Includes</i>	HANDLE MOUNTING BRACKET WD
4	563302	HANDLE D3 FNT MNT
5	542807P	SCREW MC M5X20 PAN PH MS PKT10
6	570075P	WASHER DOOR BRACKET WD (10PK)
7	570015	HANDLE MOUNTING BRACKET WD
8	570012	LIGHTPIPE SS WD
9	NS	SURROUND STRUCTURE ASSY WD60S
10	570021	SLIDE LEFT WD120 HETTICH
NI	546692P	SCREW ST 8X12MM TAB MTS PKT10
11	570030	TOP FRONT FACIA WD
12	570049	TRIM FRONT LEFT SS WD
13	570108	KIT ANTI TIP
NI	570107	KIT RAILS OB2
NI	817825P	SCREW 8X22 WAFER PHIL TV PKD
14	563100	PIN LOCK FNT HANDLE
15	563081	GRUBSCREW FRONT HANDLE



5 CONTROLS & ELECTRICAL ASSEMBLY

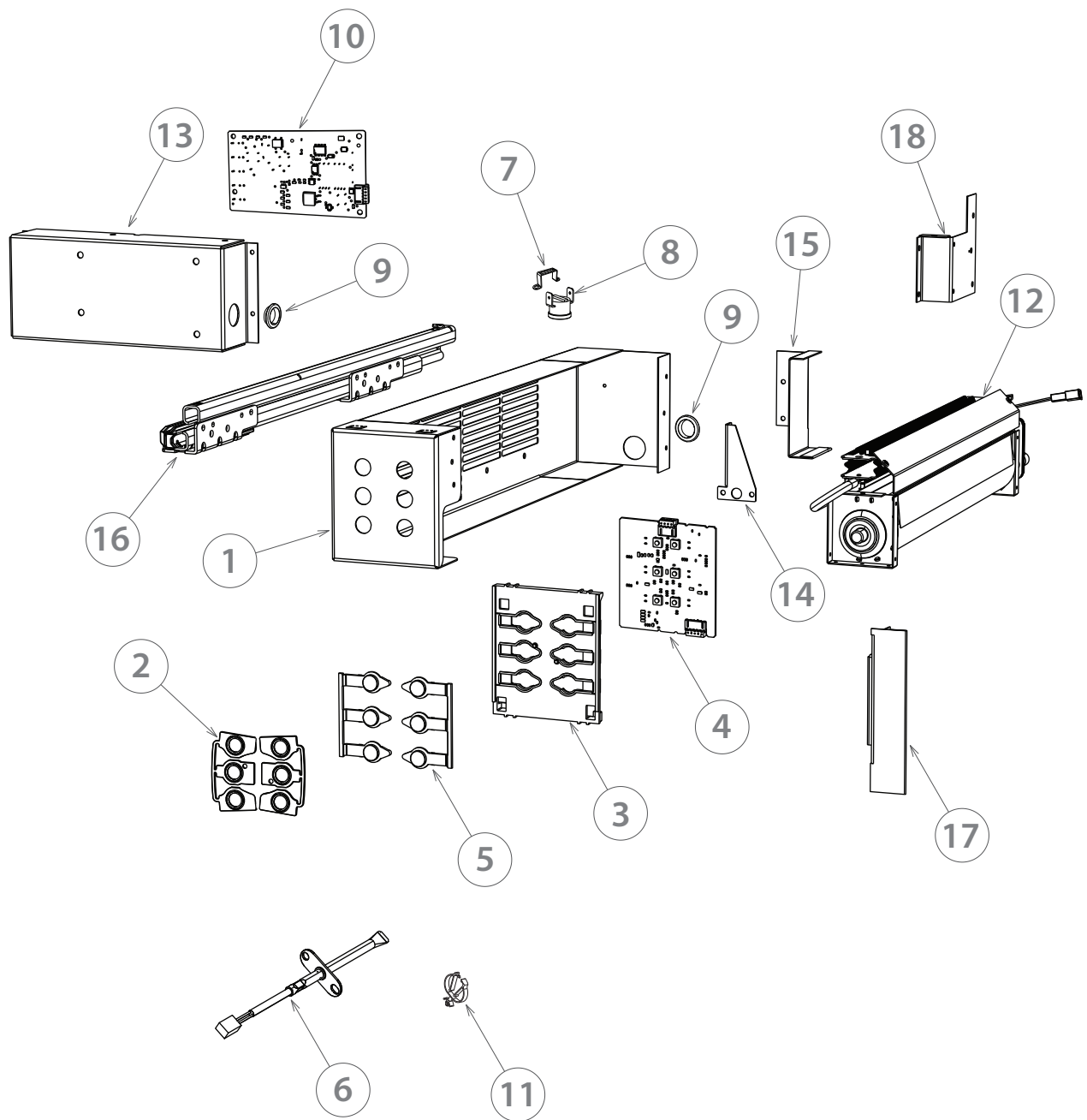

REF.	PART NUMBER	PART DESCRIPTION
1	570091	HOUSING CONTROLS WD
NI	546692P	SCREW ST 8X12MM TAB MTS PKT10
2	860539P	KIT BUTTONS/TAPE DISPLAY
	<i>Includes</i>	<i>BUTTONS DISPLAY X 2</i>
	<i>Includes</i>	<i>TAPE 3M 12.75MMX54.8M DBL SIDE X 2</i>
3	570007	HOUSING CONTROL MODULE WD
4	570047P	MODULE DISP WD ROHS SVC
5	860778	BUTTONS DISPLAY ASSY
6	545259	SENSOR OVEN TEMP CYNTEC 3
NI	556003P	SCREW ST 6X3/8 T25 PANPH PKT10
7	574132	CLIP LIMITER
8	550998	LIMITER HIGH RUNAWAY
NI	556003P	SCREW ST 6X3/8 T25 PANPH PKT10
NI	574572	HARNESS SENSOR TEMP
9	570062	EDGE PROTECTOR 19MM
NI	570111P	WASHER M4 304SS ADHSV (PKT10)
10	570040P	MODULE POWER WD ROHS SVC
NI	570061	PCB STANDOFF 10MM
11	545811P	CLIP CABLE TWIST HOLDER (PKT 5)
12	570071	HEATER BLOWER WD
13	570067	COVER POWER ELECTRONICS
14	570076	BRACKET THERMOSTAT WD
NI	556003P	SCREW ST 6X3/8 T25 PANPH PKT10
NI	570060	WARMING DRAWER HARNESS
NI	534900	TRML BLOCK-FLEX ASSY NZ AU
15	570080	SHIELD FLEX TERMINALS
NI	570064P	SCREW M4X10 TAPTITE PH PN PKT10
16	570022	SLIDE RIGHT WD120 HETTICH
NI	546692P	SCREW ST 8X12MM TAB MTS PKT10
NI	570111P	WASHER M4 304SS ADHSV (PKT10)
17	570050	TRIM FRONT RIGHT WD
18	570073	TRIM REAR RIGHT SS WD
NI	590450	BOOKSET WARM DRAWER WB60S AA
	<i>Includes</i>	<i>BOOK USR WARMER DRAWER FP AA</i>
	<i>Includes</i>	<i>BOOK INSTL WARM DRAWER FP AA</i>
	<i>Includes</i>	<i>BOOK SERVICE & WARR'TY FP/EL</i>

FISHERPAYKEL.COM

© Fisher & Paykel Appliances Ltd 2017. All rights reserved.

The product specifications in this booklet apply to the specific products and models described at the date of issue. Under our policy of continuous product improvement, these specifications may change at any time. You should therefore check with your Dealer to ensure this booklet correctly describes the product currently available.

AA

PRODUCT CODE: 81487-A 12.17