

Fisher & Paykel
appliances

customer care™

Fisher & Paykel

WASHSMART® Washer

WA80T65GW1 FP AA

Product Code: 92193-A

Parts Manual

AA

Brand:	Fisher & Paykel
Voltage:	220-240V, 50H
Model:	WA80T65GW1 FP AA
Product Code:	92193-A

Models

- The models covered by this manual are listed on the front cover.
- The information detailed in this manual is subject to change without notice. The latest version is indicated by the reprint date and replaces any earlier editions.
- The front cover picture indicates the type of product. It may not be an exact image of the model covered in the manual.

Kit Parts

Kit components are shown in *italics*. Where a part number is shown against the descriptions for these kit components, they are also available as separate items. In addition, some parts may be supplied with these kits that are not available as separate items, and are therefore either not listed, or a part number is not shown against the part description in this manual.

Parts List Key

<i>italics</i>	Kit components or parts included are shown in italics. Refer to above notes: Kit Parts.
NI	As a part reference, indicates the part is not illustrated on the diagram.
NOT USED	As a part number, indicates the diagram part reference is not used in this manual.

TOP DECK & ELECTRONICS	4
WRAPPER	6
AGITATOR & HOSES	8
INNER BOWL, OUTER BOWL & PUMP	10
MOTOR	12

Fisher & Paykel Appliances Ltd
78 Springs Road, East Tamaki,
Manukau 2013,
PO Box 58-732, Botany,
Manukau 2163,
New Zealand

Fisher & Paykel Customer Services Pty Ltd
PO Box 798, Cleveland, QLD 4163
A.C.N. 003 3335 171
19 Enterprise Street Cleveland, QLD 4163
Australia

tel: 09 273 0448
fax: 09 273 0656

tel: (07) 3826 9100
fax: (07) 3826 9164

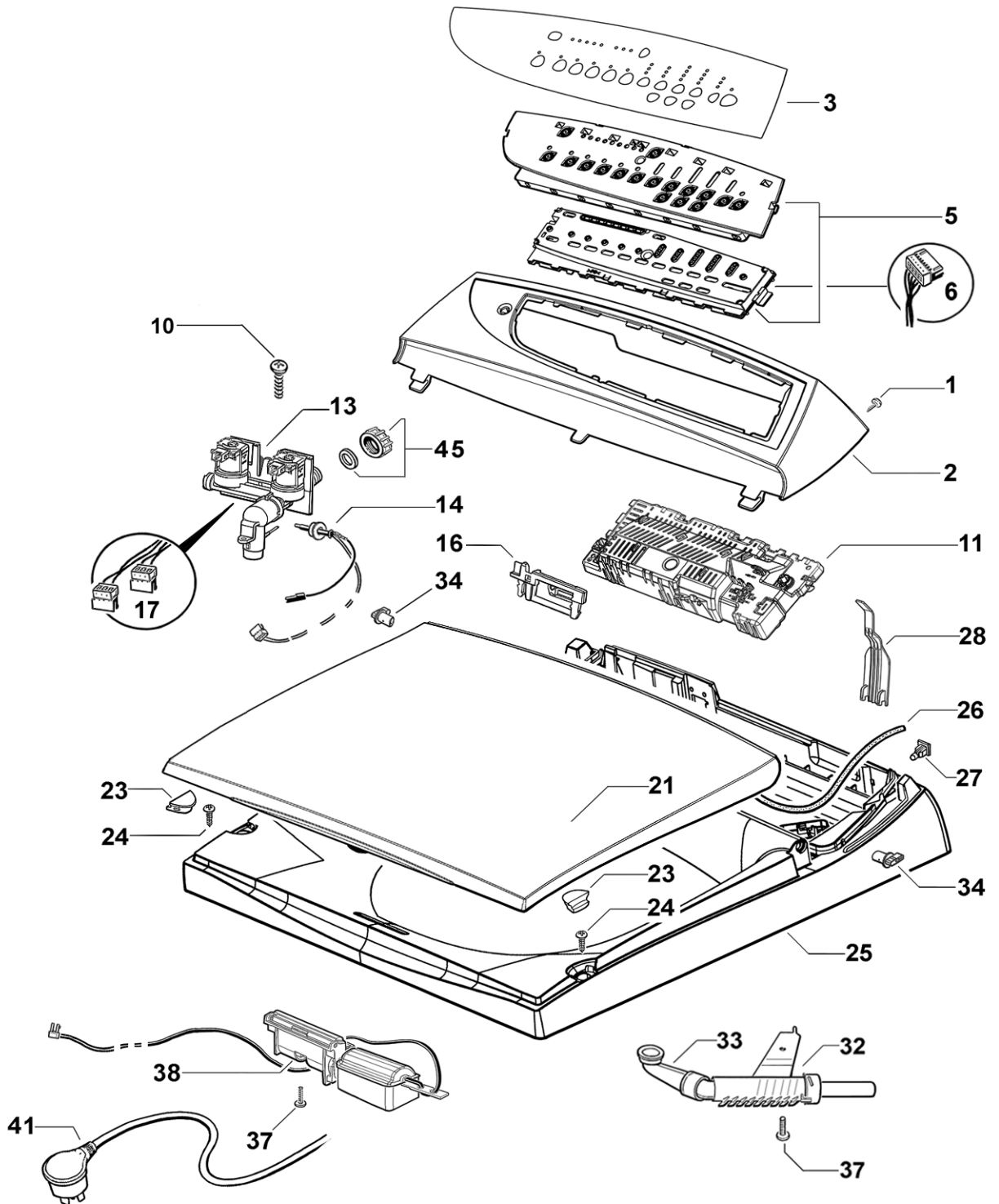

REF.	PART NUMBER	PART DESCRIPTION
1	611933P	SCREW ST 8X5/8 TA MTS PH ZNPL (PKT 10)
2	426815	CONSOLE L11 WHITE
3	424147	PANEL TOUCH G WASHSMRT
5	421098P	KIT DISPLAY GW
	<i>Includes</i>	DISPLAY ASSY GW
	<i>Includes</i>	INSERT CONSOLE
	<i>Includes</i>	INSTRUCTION SHEET
6	420176	HARNESS DISPLAY GW11
10	611986P	SCREW ST 8X20MM HILO (PKT 10)
11	421297NAP	MOD MC SD PH9 230V N ECO NZ/AU
13	421174P	VALVE INLET DUAL GW / IW VERSION 3
	<i>Includes 420897</i>	CLIP RETAINING RAST DUAL VALVE (2)
	<i>Includes</i>	THERMISTOR ASSY EPCOS
	<i>Includes</i>	GROMMET THERMISTOR 4MM
14	479452P	KIT EPCOS THERMISTOR & GROMMET UL
	<i>Includes</i>	THERMISTOR ASSY EPCOS UL
	<i>Includes</i>	GROMMET THERMISTOR 4MM
	<i>Includes</i>	LEAFLET INSTRUCTION THERMISTOR EPCOS UL
16	420738P	CLAMP HARNESS TOP DECK
17	421416	HARNESS DISP. INLET 2 VALVE
21	478070P	LID L13 WH PKD
23	426793P	BUFFER LID SD11 (PKT 2)
24	611812P	SCREW ST 10X5/8 MSH PAN PH SS430 (PKT 10)
25	420759	TOP DECK IW/GWL WH
26	426273P	GASKET CONSOLE FOAM CUT
27	422402	NUT SNAP IN SPIRE P0071/05/01/00
28	420133P	COVER WIRING TOPDECK SD11
32	420143	NOZZLE ASSY SD11
	<i>Includes</i>	BODY NOZZLE SD11
	<i>Includes</i>	PISTON NOZZLE
	<i>Includes</i>	CAP NOZZLE
	<i>Includes</i>	SPRING NOZZLE
33	425974P	ELBOW NOZZLE SD3
34	426825P	HINGE LID SD11 (PKT 2)
37	611808P	SCREW ST 8X1/2 PAN PH SS 430S (PKT 10)
38	420700P	LIDLOCK ASSY SD14
41	420826	CORD SET SD AA STRAIN RELIEF
45	388491P	CAP VALVE BLANKING
	<i>Includes 420017</i>	CONNECTOR SEAL VALVE CAP

6 WRAPPER

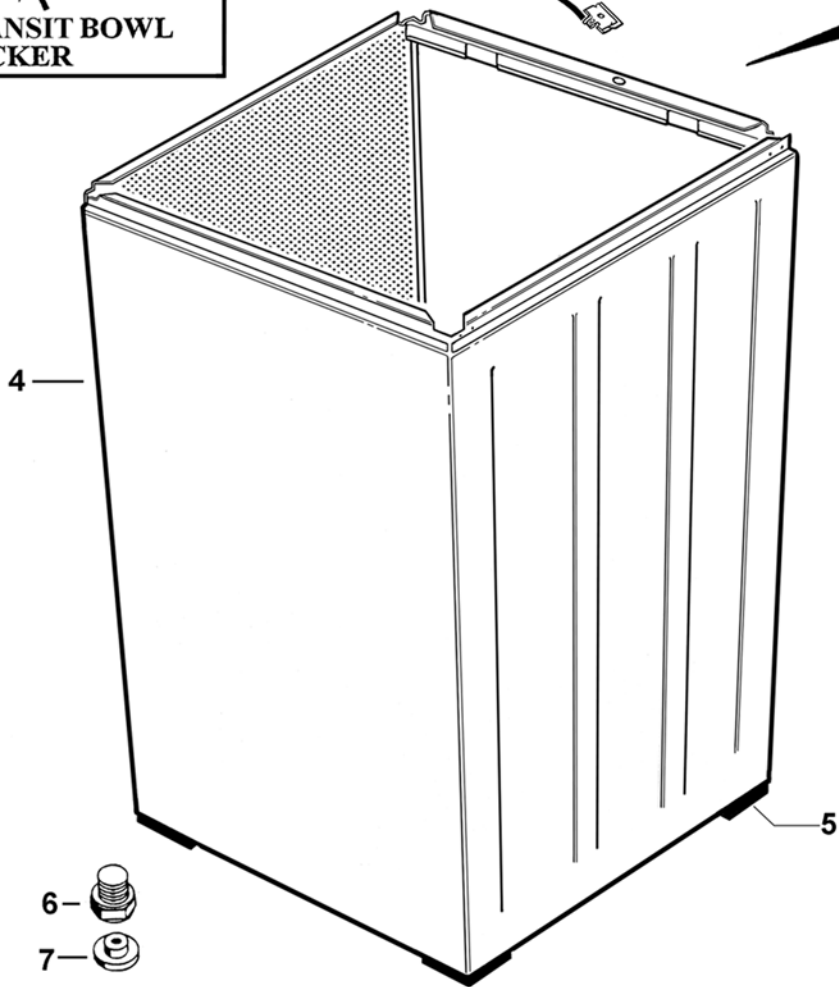
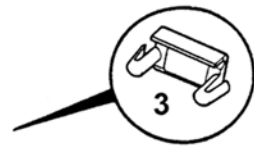
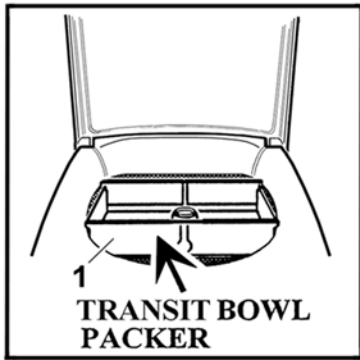

TRANSIT BASE
PACKER

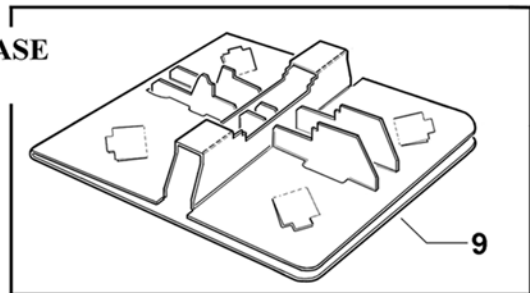

REF.	PART NUMBER	PART DESCRIPTION
1	420071	PACKER BOWL L11
2	420877	WIRE CABINET EARTH RFI CHOKE
3	426058	COVER EARTH CLIP
4	426663P	WRAPPER ASSY 7 PKD
	<i>Includes</i>	<i>WRAPPER ASSY 700 WHITE</i>
	<i>Includes 420877</i>	<i>WIRE CABINET EARTH RFI CHOKE</i>
	<i>Includes 426058</i>	<i>COVER EARTH CLIP</i>
	<i>Includes</i>	<i>CORNER CABINET BOTTOM (4)</i>
	<i>Includes</i>	<i>FOOT LEVELLING (4)</i>
	<i>Includes 479183</i>	<i>INSERT FOOT</i>
5		PART OF WRAPPER ASSY
6	472969P	KIT FOOT & INSERT
	<i>Includes</i>	<i>FOOT LEVELLING</i>
	<i>Includes</i>	<i>INSERT FOOT</i>
7	479183P	INSERT FOOT (PKT 4)
9	420181	PACKER BASE L LOCAL

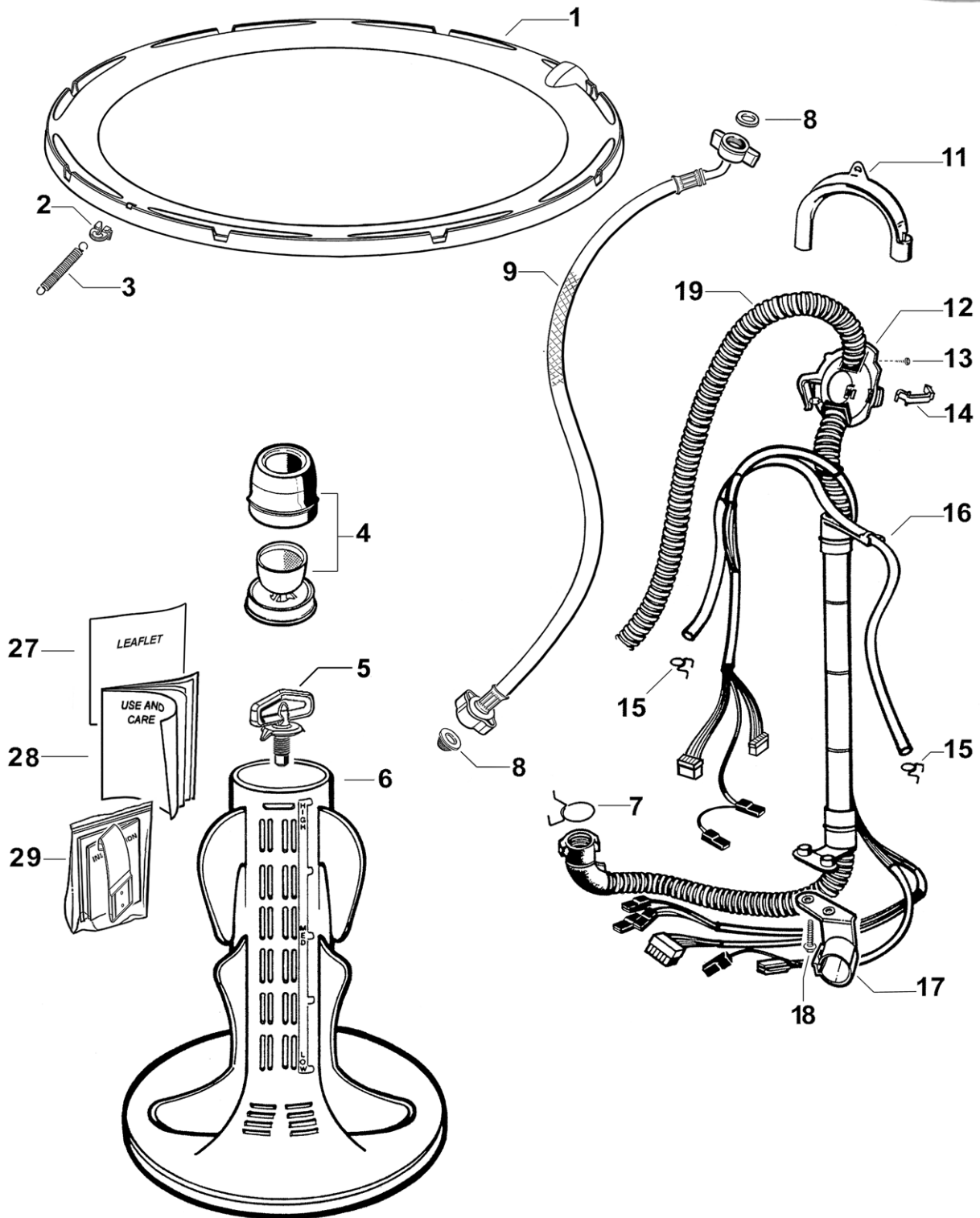

REF.	PART NUMBER	PART DESCRIPTION
1	426809P	NECK RING ASSY L11
	<i>Includes 426812</i>	<i>NECK RING L11 LT GREY</i>
	<i>Includes 420197</i>	<i>CLIP BIAS SPRING</i>
	<i>Includes 420122</i>	<i>SPRING BIAS</i>
2	420197P	CLIP BIAS SPRING SD11
3	420122P	SPRING BIAS SD11
4	426993P	DISPENSER ASSY WHITE
5	420665P	BOLT AGITATOR
6	425025P	AGITATOR PKD
7	422500	CLAMP HOSE 031.5
8	420016P	KIT FILTER / CONNECTOR SEAL
	<i>Includes 420016</i>	<i>FILTER INLET MIFLEX (2)</i>
	<i>Includes 420017</i>	<i>CONNECTOR SEAL MIFLEX (2)</i>
9	420375P	HOSE INLET ASSY MIFLEX II (10MM ID)
	<i>Includes</i>	<i>FILTER INLET PLASTIC</i>
	<i>Includes</i>	<i>CONNECTOR SEAL (2)</i>
	422680P	HOSE INLET LONG (2MX10MM ID) PKD
	<i>Includes 420016</i>	<i>FILTER INLET MIFLEX</i>
	<i>Includes 420017</i>	<i>CONNECTOR SEAL MIFLEX (2)</i>
11	420667P	GUIDE OUTLET HOSE PKD
12	426455	FIXTURE DRAIN HOSE
13	611933P	SCREW ST 8X5/8 TA MTS PH H5 (PKT 10)
14	425487	CLIP FIXTURE DRAIN HOSE
15	425611	CLAMP HOSE 08.5 TALL GRIP
16	425299	TUBE PRESSURE SENSOR SD2
17	425503	BRACKET DRAIN HOSE
18	425150P	SCREW ST 1/4X1" PLASTITE (PKT 10)
19	421424P	HOSE & HARNESS ASSY PKD
27	820303	CARD REGISTRATION FP AA
28	421384	BOOK USE & CARE WA*G NZ / AU
29	479273	KIT CATCH LID
	<i>Includes 479263</i>	<i>CATCH LID PARTIAL OPENING</i>
	<i>Includes 479278</i>	<i>TAPE FOAM DIE CUT 46X40X1</i>
	<i>Includes 479272</i>	<i>LEAFLET INSTALLATION CATCH LID</i>

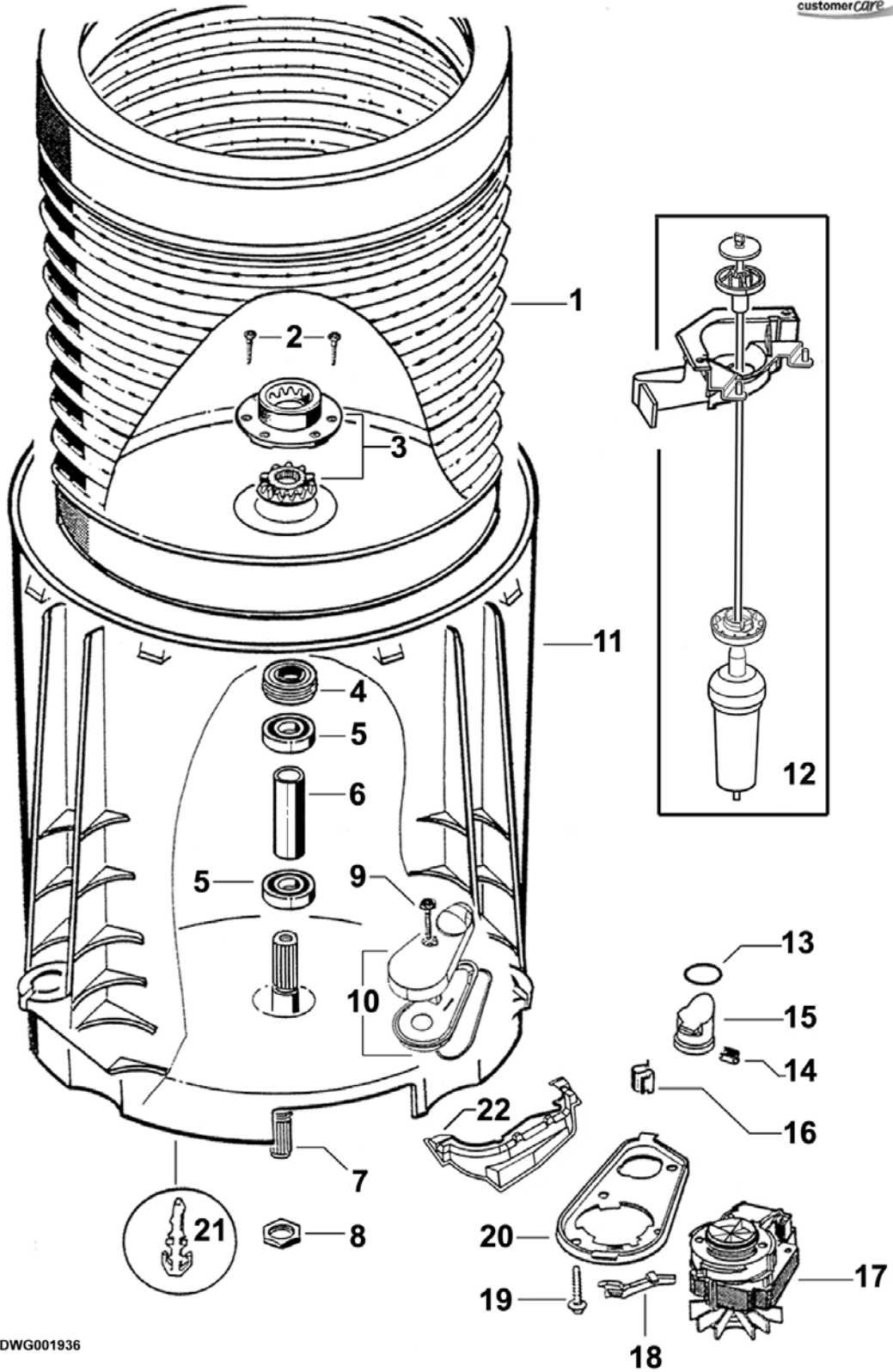

REF.	PART NUMBER	PART DESCRIPTION
1	420841P	BOWL INNER 700 ASSY PKD
	<i>Includes 425080</i>	<i>SPLINE DRIVEN</i>
	<i>Includes 425131</i>	<i>SCREW CLUTCH (3)</i>
	<i>Includes 425596</i>	<i>SPLINE DRIVE ASSY</i>
2	425131P	SCREW CLUTCH (PKT 10)
3	479318P	KIT SPLINE DRIVE
	<i>Includes 425080</i>	<i>SPLINE DRIVEN</i>
	<i>Includes 425596</i>	<i>SPLINE DRIVE ASSY</i>
4	425009P	LIPSEAL PKD
5	425006P	BEARING 6005LLU PKD
6	425007	SPACER BEARING
7	420794P	KIT SHAFT SHORTENED
	<i>Includes 420664</i>	<i>BOLT ROTOR</i>
	<i>Includes 420665</i>	<i>BOLT AGITATOR</i>
	<i>Includes 479359</i>	<i>INSTRUCTION SHEET</i>
8	425171	NUT BEARING
9	425162P	SCREW COVER (PKT 10)
10	421977P	KIT DRAIN LABYRINTH CAP/HOOD/IMPELLOR
	<i>Includes 425115</i>	<i>SEAL PUMP CAP</i>
	<i>Includes 421976</i>	<i>CAP & HOOD PUMP ASSY LABYRINTH</i>
11	421099P	BOWL OUTER KIT LARGE
	<i>Includes 425006</i>	<i>BEARING 6005LLU</i>
	<i>Includes 425007</i>	<i>SPACER BEARING</i>
	<i>Includes 425009</i>	<i>LIP SEAL</i>
	<i>Includes 425115</i>	<i>SEAL PUMP CAP</i>
	<i>Includes 425162</i>	<i>SCREW COVER</i>
	<i>Includes 421976</i>	<i>CAP & HOOD PUMP ASSY LABYRINTH</i>
	<i>Includes 421094</i>	<i>SHIELD MOTOR UL (BLACK)</i>
	<i>Includes 425961</i>	<i>SHIELD MOTOR SD UL (BROWN)</i>
	<i>Includes 426145</i>	<i>TUBE BUFFER SHIELD MOTOR UL (4)</i>
	<i>Includes</i>	<i>SHEET INSTALLATION INSTRUCTION</i>
12	420952P	SUSPENSION ASSY DBLE SQUASH (PKT 4)
13	425149	SEAL O RING PRESSURE CHAMBER
14	613710P	CLIP EDGE
15	425097	PLUG PRESSURE CHAMBER
16	613709P	CLIP PIPE UNITED CARR FT19280-ZNPL (PKT 10)
17	420324P	PUMP DRAIN 230V 50Hz
	<i>Includes 420319</i>	<i>IMPELLOR INSERT ASSEMBLY</i>
18	425128P	CLIP PUMP RETAINING
19	425150P	SCREW ST 1/4X1" PLASTITE (PKT 10)
20	425028P	BRACKET PUMP
21	472867P	CLIP WIRING OUTER BOWL
22	NOT USED	ITEM NOT USED IN THIS MODEL

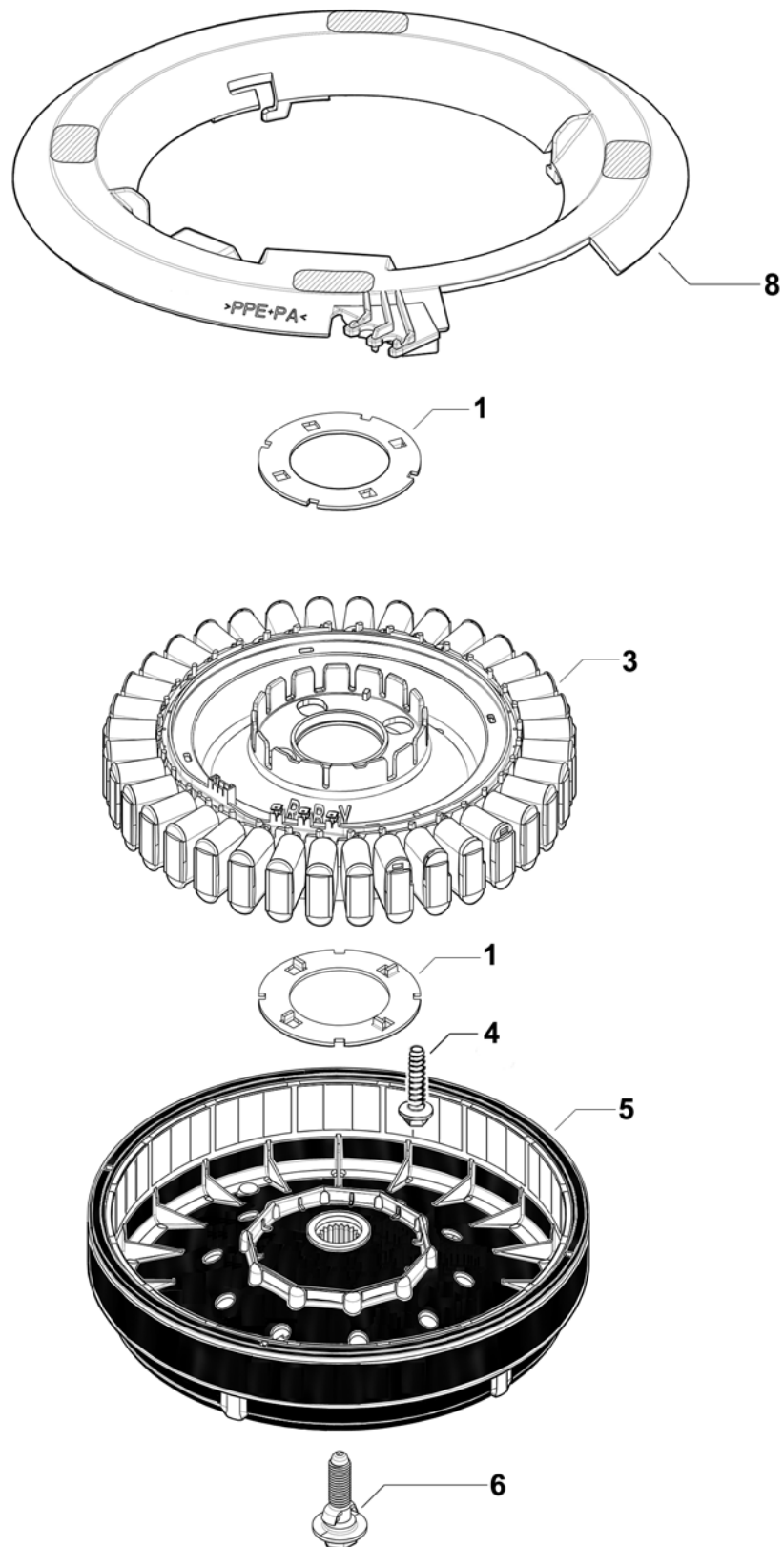

REF.	PART NUMBER	PART DESCRIPTION
1	426174P	CLAMP PLATE STATOR LANCED (PAIR)
3	438516P	STATOR ASSEMBLY SPARES
	<i>Includes</i>	<i>STATOR ASSY 0.6 AL</i>
4	426835P	SCREW STATOR (PKT 10)
5	438503P	ROTOR ASSY SPARES
	<i>Includes 420664</i>	<i>BOLT ROTOR</i>
6	420664P	BOLT ROTOR
8	421094P	SHIELD MOTOR UL

Fisher & Paykel
appliances

customer care™

www.fisherpaykel.co.nz
www.fisherpaykel.com.au

Fisher & Paykel

Copyright © Fisher & Paykel 2011. All rights reserved.

The product specifications in this booklet apply to the specific products and models described at the date of issue. Under our policy of continuous product improvement, these specifications may change at any time. You should therefore check with your Dealer to ensure this booklet correctly describes the product currently available.